

# Application of Hardware in the Loop technology for testing servo drives with synchronous motor

Dominik Rybarczyk\*, Piotr Owczarek\*, Jarosław Gośliński\*\*

\*Faculty of Mechanical Engineering and Management, Poznań University of Technology

\*\*Faculty of Electrical Engineering, Poznań University of Technology

**Abstract:** The article describes the proportional valve with synchronous motor type PMSM used in electrohydraulic servo drive. System has been tested using the Hardware in the Loop technique. It means that most of the elements, in addition to the synchronous motor, were implemented on the PLC as a discrete model. The time characteristics of the servo drive were checked by a step-response method.

**Keywords:** electrohydraulic servo drives, synchronous motor, hardware in the loop

In the few last years, many efforts have been taken in order to improve the construction and ways of control electrohydraulic servo valves. Nowadays, most of the electrohydraulic servo drives are built on the basis of proportional valves, because of their low costs (in opposite to the servo valves). Their main disadvantage is the relatively low dynamic parameters. Without this problem are electrohydraulic servo valves. Unfortunately, they are characterized by high cost. For this reason, it is necessary to search for new solutions, which relate universality and high dynamic of the electrohydraulic servo valves.

In the presented here work, authors proposed proportional valve, whose slider was controlled by a synchronous motor. Proposed valve has been tested using a rapid prototyping control method and hardware in the loop technology.

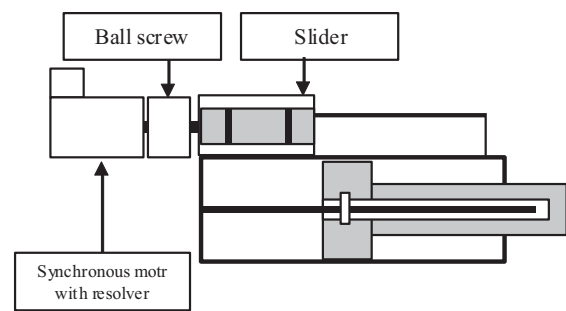
## 1. Current state of the art

So far, scientific publications focused on the use of stepper motors or DC motors to control the hydraulic valves. The usage of electrohydraulic servo drive with stepping motor was described in [1]. The stepping motor was used to control the valve slider. Authors described the construction and some methods of control of this kind of drives. The dynamic characteristics of servo drives with stepping motor was described in [2]. Principles of selecting electrohydraulic stepping motors for electrohydraulic servo valves were presented in [3]. The design where drive based on a servomotor and cam used in the proportional valve was described in [4].

## 2. Construction of the proportional valve with synchronous motor

The construction of the proposed servo valve is based on the construction of the proportional valve. In the typical

proportional valve, the slider is used for flow control. The movement of the slider is controlled by two coils, placed on opposite sides of the slider. In the case of the described valve, the coils have been replaced by a low-power synchronous motor, connected to the slider by a ball screw (fig. 1). Authors used a resolver, mounted on the motor shaft for measurement of the slider position. The resolver worked with resolution up to 4200 pulses/rev.



**Fig. 1.** Electrohydraulic servo valves with synchronous motor  
**Rys. 1.** Elektrohydrauliczny zawór z silnikiem synchronicznym

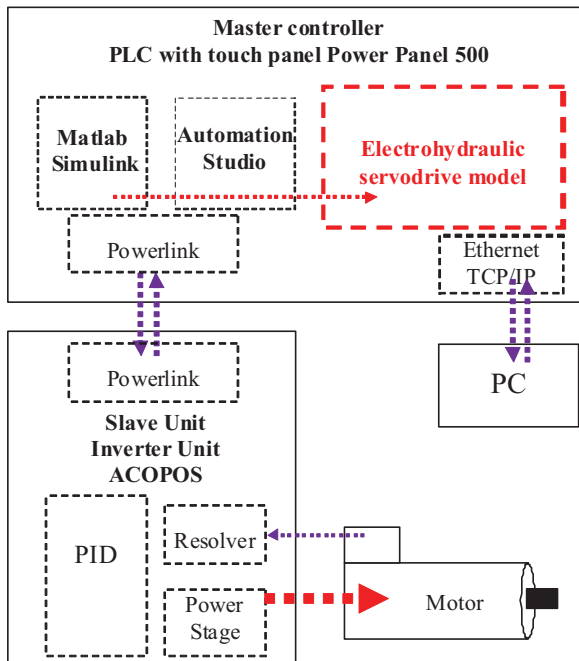
The proposed valve actuator was a permanent magnets synchronous motor type (PMSM). The motor has controlled by an servo inverter, generated independent signals for each motor phase (fig. 2). The advantage of this type of motor, opposed to the stepper motor, is much more dynamic parameters, together with high torque at the shaft over the entire range of velocity.



**Fig. 2.** Synchronous motor type PMSM used in servo valve  
**Rys. 2.** Zastosowany w zaworze silnik synchroniczny z magnesami trwałymi

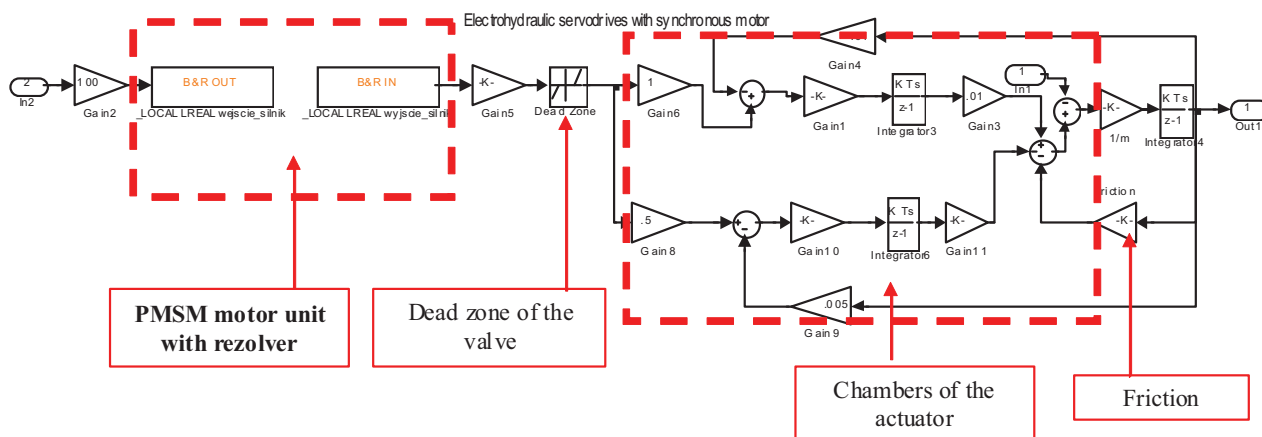
### 3. Testbed

Checking the effectiveness of the proposed design was made by using the hardware in the loop technology. This technique allows for testing the different control methods by using the object model instead of the real device. In this way the real object was protected from the potential error or damage (fig. 3).

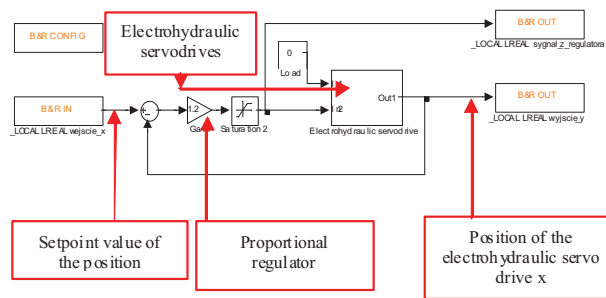


**Fig. 3.** The control system schematic  
**Rys. 3.** Schemat układu sterowania

For this aim, electrohydraulic servo drive have been modeled (fig. 4). The model consisted of a linear model of the hydraulic actuator with two, no symmetrical chambers (sided cylinder). Whole drive unit was controlled the proportional valve with synchronous motor. In addition, the valve dead zone have been implemented. The described model did not include non-linear properties of the servo drive (fig. 5). The only real object of the whole tested system was the motor and measuring system which was the resolver.



**Fig. 5.** Model of electrohydraulic servodrives  
**Rys. 5.** Model serwonapędu elektrohydraulicznego



**Fig. 4.** Model of electrohydraulic servo drives control system  
**Rys. 4.** Model układu sterowania napędu elektrohydraulicznego

Authors used PMSM B&R company motor type 8LSA25. The motor was controlled by the inverter type ACOPOS [6] (fig. 6). For safety reason, motor was supplied by 24 V, which greatly reduced its dynamics parameters. In the real object, controlled voltage of the motor should be higher – 400 V. As the master controller, authors used a PLC unit with touch screen type Power Panel 500 [6]. The PLC unit was equipped with a processor, with core based on Intel Atom 1.6 and real-time system type Automation Runtime [6] (fig. 7). The model electrohydraulic servo drives was implemented in the master PLC.

System was modeled by using Matlab Simulink software. In order to connect the real object, which was motor, and the other servo drives components, it became necessary to transfer the model to the PLC. For this regard, author used Simulink Coder library and Automation Target for Simulink library (B&R). This allowed to recompile the model of the servo drive to the C code, and then to implement it as one of the task class in the CPU unit. Due to the discrete work of the industrial controller, it was required to discretize the continuous model of electrohydraulic servo drive. The discrete time base was  $T = 0.0008$  s. The time base for the main system clock driver and the communication interface, between the master controller and the inverter, was  $T = 400$  s.

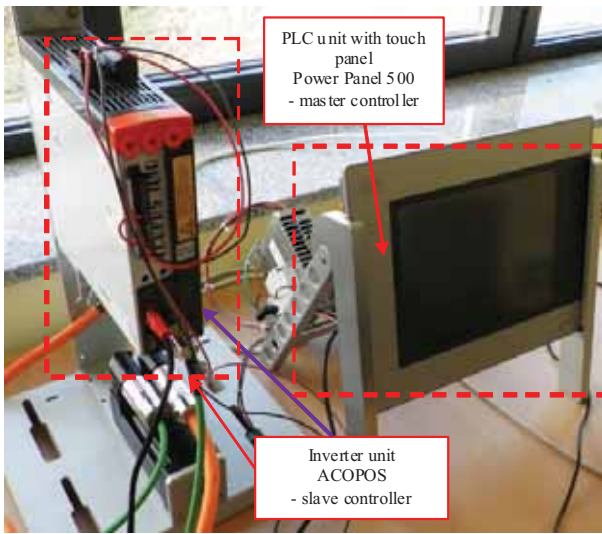


Fig. 6. The experimental stand

Rys. 6. Stanowisko badawcze

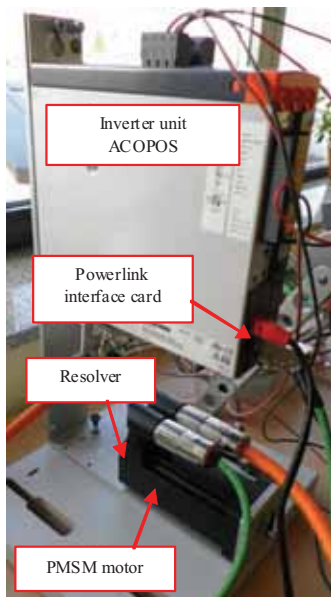


Fig. 7. ACOPOS – inverter unit [6]

Rys. 7. Serwofalownik ACOPOS [6]

#### 4. Experimental tests

The study aimed to validate the work of the proposed control methods before testing on the actual object. Positioning system was tested in the absence of external load.

To determine the object time characteristics parameters, the step response method was used. On the proportional valve a stepwise position signal was gave.

The resulting waveforms shows:

- The given position signal,
- The actual position of the servo drive,
- The given position of the motor shaft signal,

- The position of the motor shaft read from the resolver unit,
- The actual velocity of the motor.

In order to avoid the appearance of stick-slip phenomenon, the slide was fitted in the oscillatory motion (dither) (fig. 8). Otherwise the slider was protected from deadlock in the event of adverse forces.

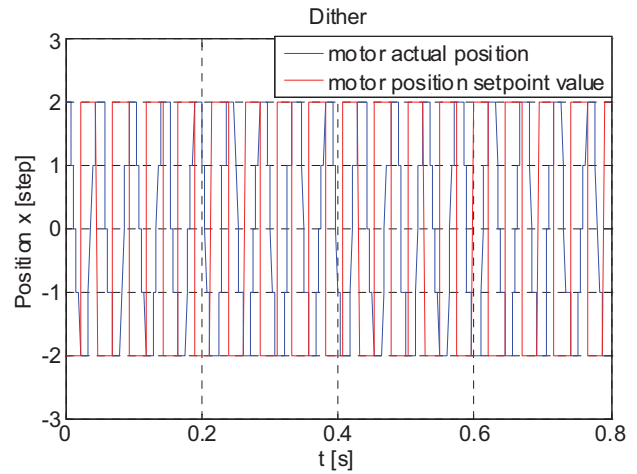


Fig. 8. Dither signal

Rys. 8. Sygnał oscylacyjny dither

The controller parameters were tuned using the Ziegler-Nichols method. The values of individual P coefficients were: the gain  $k_p = 2$  and  $k_p = 0.8$ . In the case of the  $k_p = 0.8$  overshoot has not occurred.

The experiment results are shown in the charts below (fig. 9–14).

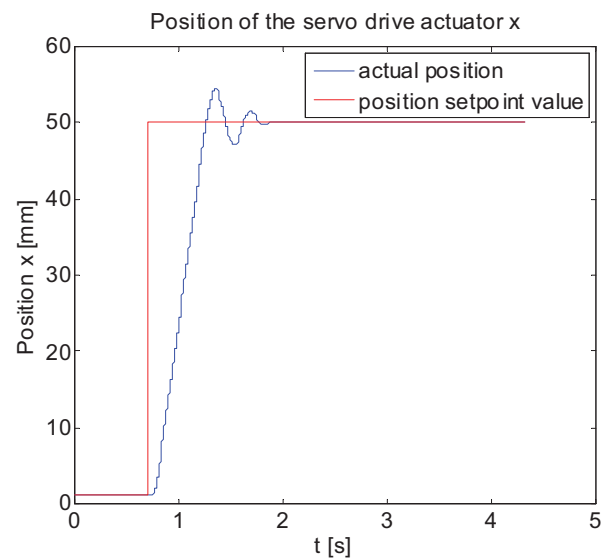
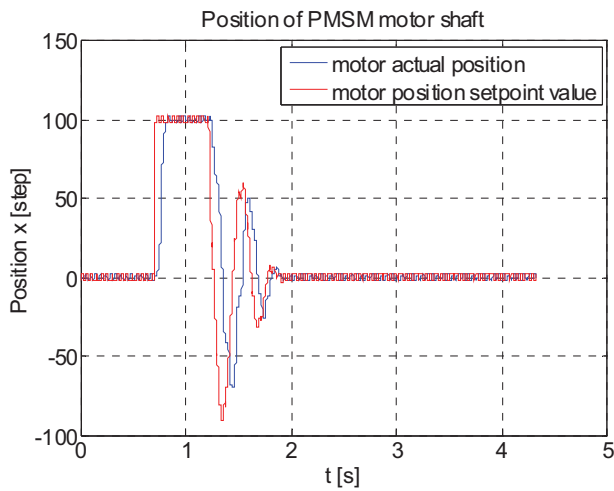


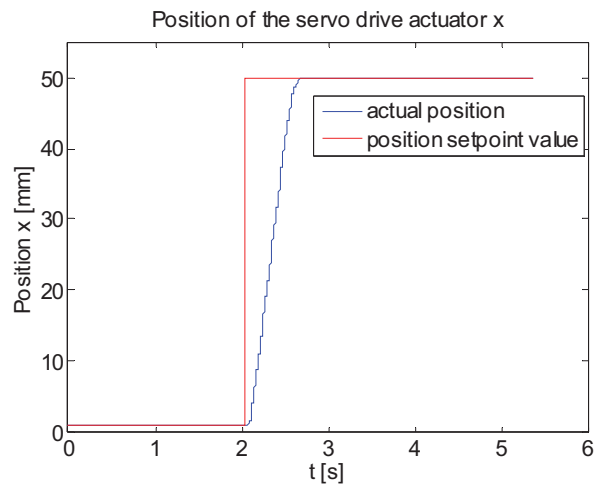
Fig. 9. Movement of the servo drive actuator (step response,  $k_p = 2$ )

Rys. 9. Ruch tłoka serwonapędu elektrohydraulicznego (odpowiedź skokowa, wzmocnienie  $k_p = 2$ )



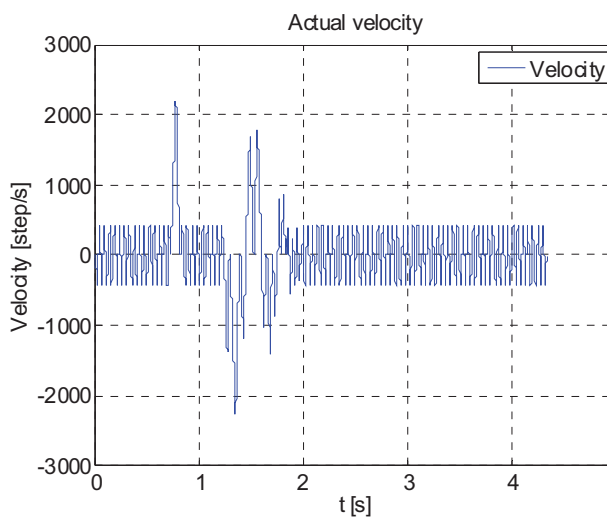
**Fig. 10.** Movement of the motor shaft – position (step response,  $k_p = 2$ )

**Rys. 10.** Ruch wału silnika – pozycjonowanie (odpowiedź skokowa, wzmacnienie  $k_p = 2$ )



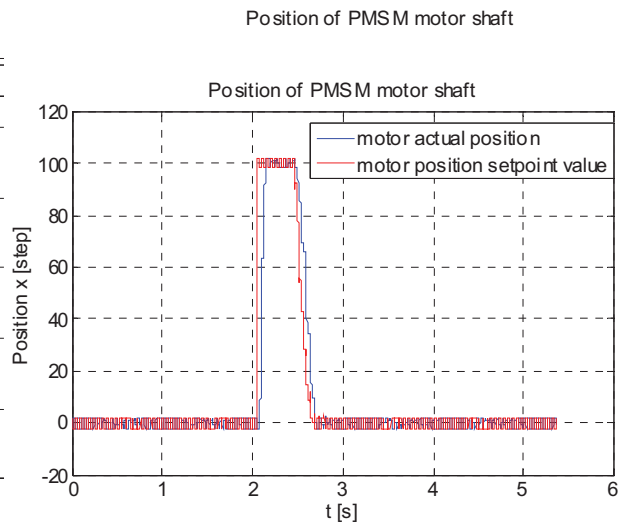
**Fig. 12.** Movement of the servo drive actuator (step response,  $k_p = 0,8$ )

**Rys. 12.** Ruch tłoka serwonapędu (odpowiedź skokowa, wzmacnienie  $k_p = 0,8$ )



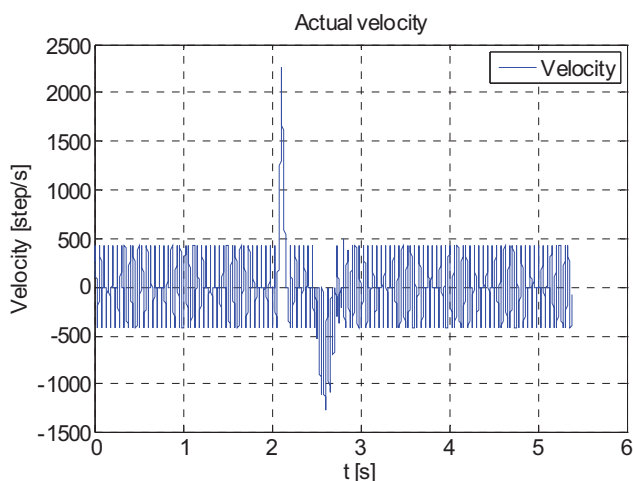
**Fig. 11.** Movement of the motor shaft – velocity (step response,  $k_p = 2$ )

**Rys. 11.** Ruch wału silnika – prędkość (odpowiedź skokowa, wzmacnienie  $k_p = 2$ )



**Fig. 13.** Movement of the motor shaft – position (step response,  $k_p = 0,8$ )

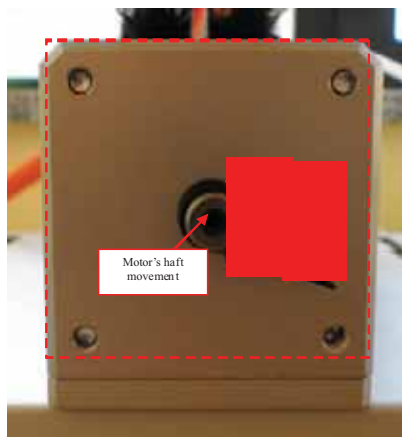
**Rys. 13.** Ruch wału silnika – pozycjonowanie (odpowiedź skokowa, wzmacnienie  $k_p = 0,8$ )



**Fig. 14.** Movement of the motor shaft – velocity (step response,  $k_p = 0.8$ )

**Rys. 14.** Ruch wału silnika – prędkość (odpowiedź skokowa, wzmacnienie  $k_p = 0,8$ )

The waveforms (fig. 10, 12) have shown inertia between given setpoint signal value and response of the motor. This is due to the supply voltage of only 24 V, which has not provide the full dynamics of the used motor (in the future, the motor will be powered from 400 V three-phase voltage).



**Fig. 15.** Movement of the motor's shaft

**Rys. 15.** Ruch wału silnika

Additional, the waveforms were shown on a touch panel screen of the central CPU unit (fig. 16).



**Fig. 16.** A visualization

**Rys. 16.** Wizualizacja

## 5. Conclusion

The stepper motors and DC motors were used in control of slider movement. However, there are still missing publications concerning on use of the synchronous motor in the hydraulic valves. The research was executed to verify the use of its capabilities in electrohydraulic servo control.

Thanks to use of the powerful synchronous servo motor it will be possible to increase the dynamics parameters of the proportional valve. Because of the used Hardware in the Loop technology, the real object have been protected from damaged arising from incorrect operation of the control system. Also, the whole control system was closed in one type control environment (Automation Studio) that may help the work of future developers.

The authors will continue research of the using the servo valves with synchronous motor. Verification requires first and foremost the system behavior under conditions of variable load and the use of nonlinear models. Also there is important to test the proposal valve on the real servo drive. Ongoing studies are aimed at designing a control algorithm, which can be implemented in an embedded system.

## Acknowledgements

The work described in this paper was supported by the Polish Ministry of Science and Education between 2009–2012 as a grant No. N502 260737.

## References

1. Milecki A., *Zasady sterowania silnikiem skokowym w układach suwakowych wzmacniaczy hydraulicznych*, *Maszyny Górnicze*, 1996, No. 56, 92–101.
2. Milecki A., *Właściwości dynamiczne serwonapędów elektrohydraulicznych z silnikami skokowymi*, "Pomiary Automatyka Robotyka", 1997, No. 5–6, 60–64.
3. Milecki A., *Zasady doboru silnika skokowego do sterowania suwaka wzmacniacza hydraulicznego*, „Hydraulika i Pneumatyka”, 1997, No. 2, 10–13.
4. Milecki A., Myszkowski A., *The usage of electrohydraulic servo drive units with stepping motor in low velocity mechatronic drives*, Proceedings of the 3rd International Conference Mechatronics, Robotics and Biomechanics, 10-12.09.2001, Trest, Czech Republic, 215–220.
5. Wiegandt Marco, *Development of a servomotor driven proportional valve*, 7th International Fluid Power Conference Aachen, 2010.
6. [www.br-automation.com] ■

## Testowanie elektrohydraulicznego serwonapędu z silnikiem synchronicznym w systemie Hardware in the loop

**Streszczenie:** Artykuł opisuje zawór proporcjonalny, w którym elementem zadającym jest silnik synchroniczny typu PMSM. Zawór steruje siłownikiem hydraulicznym. Układ przetestowano przy użyciu techniki Hardware in the Loop. W tym celu większość elementów, oprócz silnika synchronicznego zaimplementowano na sterowniku PLC jako model dyskretny. Podczas testów zebrano charakterystyki czasowe układu.

**Słowa kluczowe:** serwonapęd elektrohydrauliczny, serwozawór elektrohydrauliczny, silnik synchroniczny, hardware in the loop

### Dominik Rybarczyk, MSc

Assistant in Division of Mechatronics Devices in Poznań University of Technology. His research interests include design of mechatronic devices, control of electrohydraulic servo drives, control of nonlinear object and artificial intelligence methods.  
e-mail: dominik.rybarczyk@put.poznan.pl



### Piotr Owczarek, MSc

Assistant in Division of Mechatronics Devices in Poznań University of Technology. His research interests include modern methods of digital image processing, artificial intelligence methods, design of electronic devices and mechatronic devices.  
e-mail: piotr.owczarek@put.poznan.pl



### Jarosław Gośliński, MSc

Received the MSc degree in control engineering and robotics from Poznań University of Technology (Poland) in 2011. He is currently a PhD student at the same university. His research interests include signal filtering and processing, MEMS sensors, state observers, control of nonlinear and underactuated objects, swarm robotics and cyber – physical systems.  
e-mail: jaroslaw.goslinski@doctorate.put.poznan.pl

