

Kinematics of underwater inspection robot

Mariusz Giergiel*, Krzysztof Kurc**, Piotr Małka*, Tomasz Buratowski*, Dariusz Szybicki**

*AGH University of Science and Technology

**Rzeszow University of Technology

Abstract: The article presents the issues associated with modeling and numerical verification of a kinematics inspection robot for diagnostic and maintenance tanks with liquid. The robot has been constructed at the Department of Robotics and Mechatronics of AGH in frames of the grant financed by NCBiR. The analysis of the kinematic was drawn using available and described in the literature mathematical methods, as well as based on existing robots designs. Structural solutions applied enable to control two crawler tracks, module cleaning the bottom of tank and the diagnostic module. Verification of the kinematic model drawn up was carried out with use engineering methods and development software MATLAB. Received results were presented as mathematical equations and simulations illustrated in the form of characteristics depicting kinematic parameters of the robot's motion. The work also presents directions of further research on the constructed robot.

Keywords: mobile robot, kinematics, inspection robot, underwater robot

1. Introduction

The project of robot for inspection and diagnostics of tanks with liquids is constructed at the Department of Robotics and Mechatronic of AGH. It's created in cooperation with the Municipal Enterprise MPWiK SA of water supply systems and sewage system. Its aim is to develop the original construction of inspection machine enabling to determine the technical condition of concrete construction of storage liquid tanks (most often water). The design fundamental assumption: work in conditions of souse in liquid at depths up to several.

Fulfilling this assumption will have a fundamental influence on the reduction costs of the inspection procedure because existing methods require most often emptying tanks, what carries behind long (about one month) stoppages. It next burdens the company budget, which is forced to turn off the tank/s from use.

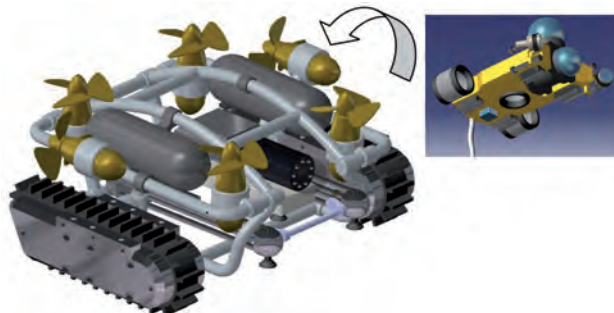

Fig. 1. Inspection robot with the diagnostic-monitoring module

Rys. 1. Robot inspekcyjny z modulem diagnostyczno-obszernym

Other advantages of replacing traditional methods of thaw inspection robot are: faster inspection, greater work security, and wider range of available inspection methods. The article presents one element of the structural-research procedure that is drawing the model of kinematics along in with numerical verification.

2. Description of the robot construction and working space

The inspection robot is constructed from tubular elements allowing for the wheelbase change. Crawler track tracks were used to the drive with developed transmission gears and propellers, their structure allows for works up to 30 m underwater. Additionally the robot is equipped with the diagnostic-monitoring module used for observation the tank above the robot height. Equipped is with 3 cameras (2 for observation, 1 for the docking with home station), 2 rotating drives and sensors laser.



Fig. 2. Tanks for storing water – MPWiK Cracow

Rys. 2. Zbiorniki do magazynowania wody pitnej – MPWiK SA Kraków

The inspection robot is intended for diagnostics and observation of tanks with liquids. Cooperation with MPWiK SA in Cracow [7] enables verifications and testing the constructed robot in real terms. Cracow water supply systems have a dozen of tanks for storing water (among others the biggest in Europe about diameter of 34 m). They require repeated reviews and expert opinions, applying the constructed robot will enable to streamline these activities, and will reduce the costs of these type actions.

3. Modeling the kinematics of inspection robot

Crawler track driving systems are arrangements, to which involves a different type of variables in time. Description of the crawler track movement in real conditions with uneven ground on changeable parameters, is very complex. The detailed mathematical description of the move of

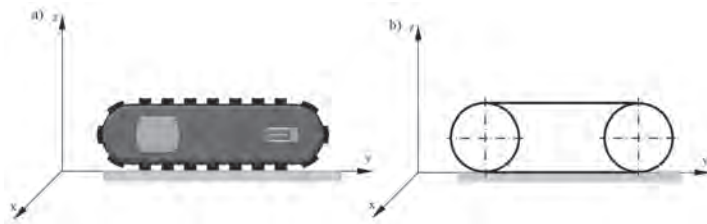

Fig. 3. a) CAD Model, b) Simplified Model

Rys. 3. a) Model CAD, b) Model uproszczony

individual crawler track points is so compound that it is necessary to apply simplified models. Crawler tracks (fig. 3a) in the very simplification it is possible to model, as the non-stretch tape about determined shape by the drive wheel, stretching wheel and no deformable ground (fig. 3b) [1–4].

Apart from widely applied crawler tracks constructed from links, appear also crawler tracks made from the elastomer belt. They constitute one element along with clutches. Driving arrangement of the analyzed crawler track robot are two driving modules (fig. 4).

Specifications:

- height: 100 mm,
- width: 90 mm,
- length: 380 mm,
- speed up to 9.75 m/min,
- maximum load: 45 kg,
- water resistance to the depth 30 m,
- mass: stainless steel 12.25 kg.



Fig. 4. Crawler tracks – model CAD

Rys. 4. Gąsienice – model CAD

Basic inside sub-assemblies (fig. 5) of each module:

- driving engine
- planetary transmission
- conical transmission
- leading transmission

Individual ratio of these transmissions:

- $i_1 = 66 : 1$ – transferring the planetary transmission,
- $i_2 = 2 : 1$ – transferring the conical transmission,
- $i_3 = 2 : 1$ – transferring the leading transmission.

Total ratio the driving module:

$$i = 264 : 1.$$

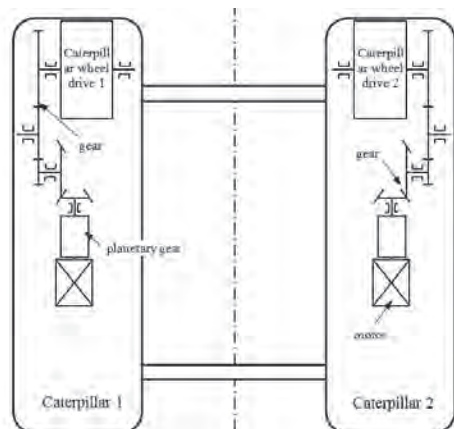

Fig. 5. Drivetrain

Rys. 5. Układ przeniesienia napędu

For the description of motion points on the crawler track circumference for the simplified model (fig. 6) two systems of coordinates were accepted. Arrangements y, z is the motionless arrangement associated with the ground, arrangement y_0, z_0 is movable arrangement associated with vehicle [1, 2, 5, 6].

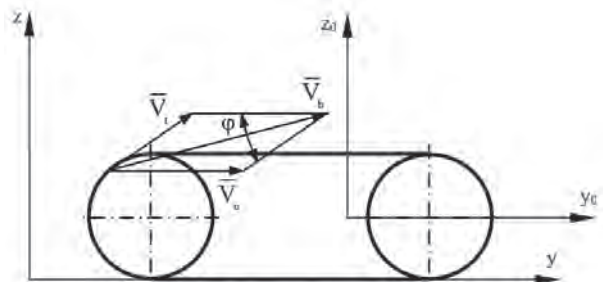

Fig. 6. Simplified model of the crawler track track

Rys. 6. Uproszczony model gąsienicy

The movement of any crawler track point is composition of two movements (fig. 6):

- relative move, of the agreement y_0, z_0 ,
- transportation move relative to the immovable arrangement y, z .

The absolute speed of any point on the crawler track circumference is equal to the sum of geometrical transportation speed and relative speed.

$$V_{by} = V_u + V_t \cos \varphi \quad (1)$$

$$V_{bz} = V_t \sin \varphi \quad (2)$$

$$V_b = \sqrt{V_{by}^2 + V_{bz}^2} = \sqrt{V_u^2 + V_t^2 + 2V_u V_t \cos \varphi} \quad (3)$$

where: V_u – speed of transportation, V_t – relative speed of any point on the crawler track circumference, V_b – absolute speed of the point on crawler track circumference, φ – angle between vectors V_t and V_u .

In case when $\varphi = \pi$, that is when points of the crawler track circumference contact with the ground, it is possible to write.

$$V_b = V_u + V_t \quad (4)$$

3.1. Slide crawler track

When transferring of the load-bearing crawler track segment appears relative to ground, then the effect of slip occurs [1, 5, 6]. Mainly for the crawler track slide affects the following factors:

- ownerships of the ground,
- appearing driving force,
- type and placing clutches on the crawler track track.

Appearing in the crawler track arrangement, the driving force causes appear of cutting powers in the ground. The re-

relationship between appearing factors it is possible to determine relations by:

$$P_n = 10^6 b \int_0^L \tau_x dx \quad (5)$$

where: P_n – driving force, b – width of the crawler track, L – length of the load-bearing of the crawler track segment, τ_x – stresses cutting in the soft ground.

Assuming that the course of parallel deformations to the ground is linear, it is possible to express these deformations by:

$$\Delta l_x = x s_b \quad (6)$$

where: s_b – slip, x – distance of the place, for which the slip is calculated from the point of crawler track contact with ground, the greatest slip appears for $x = L$.

Therefore, it is possible to express the slip by:

$$s_b = \frac{\Delta l_x}{x} = \frac{\Delta l_{max}}{L} \quad (7)$$

3.2. Kinematics of turning

It is possible to define the turn of crawler track vehicle as the flat movement, which is a sequence of turns around next momentary axes of rotation. The center of turn creates tracks on the plain of next rotation axes and it can be fixed point for the movement about constant radius or line.

Turn in crawler track vehicles depending on the direction and value of driving forces and braking (P_2 and P_1) can be carried out in few ways.

When the speed of running crawler track is reduced in the relationship to run (fig. 8a) by braking, a turn appears about the small radius R . On running crawler tracks then operate oblong tangent forces about direction opposite direction to the movement of the crawler track vehicle. In that kind of turn on the vehicle operate two forces, brake force P_1 in the running crawler track and driving force P_2 about the direction of vehicle movement in the running crawler track.

In case of disconnection the running crawler track drive (fig. 8b) appears turn about the great radius. Then only P_2 force of the running crawler track appears.

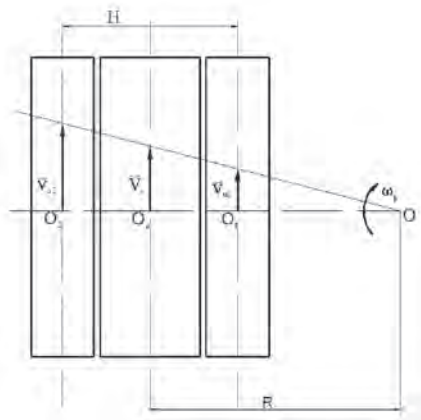

Fig. 7. Kinematic diagram of the crawler track vehicle turn without a slip

Rys. 7. Schemat kinematyczny skrótu pojazdu gąsienicowego bez poślizgu

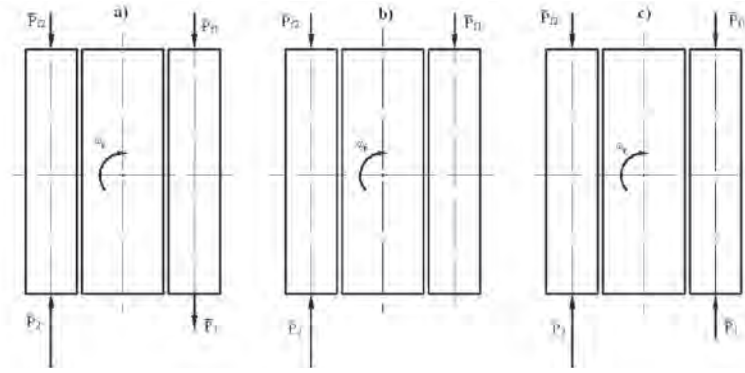

Fig. 8. Possible variants of the crawler track vehicle turn
Rys. 8. Możliwe warianty skrótu pojazdu gąsienicowego

At appearance of great resistances progressive move and low resistances of the turn, may appear case that P_1 force of the running crawler track have direction in accordance with direction of the ride (fig. 8c).

3.3. Kinematics equation

Prędkość punktu C, znajdującego się na osi symetrii pojazdu gąsienicowego, przyjętego jako środek masy pojazdu [1–3, 5, 6], wynosi:

$$V_C = \frac{r\dot{\alpha}_1(1-s_1) + r_2\dot{\alpha}_2(1+s_2)}{2} \quad (8)$$

Nie uwzględniając poślizgu:

$$V_C = \frac{r\dot{\alpha}_1 + r\dot{\alpha}_2}{2} \quad (9)$$

Components of the speed point C it is possible to write as:

$$\dot{x}_C = V_C \cos \beta \quad (10)$$

$$\dot{y}_C = V_C \sin \beta \quad (11)$$

After taking into account the relation (8) received the equation of simple kinematic task:

$$\dot{x}_C = \frac{r\dot{\alpha}_1(1-s_1) + r\dot{\alpha}_2(1-s_2)}{2} \cos \beta \quad (12)$$

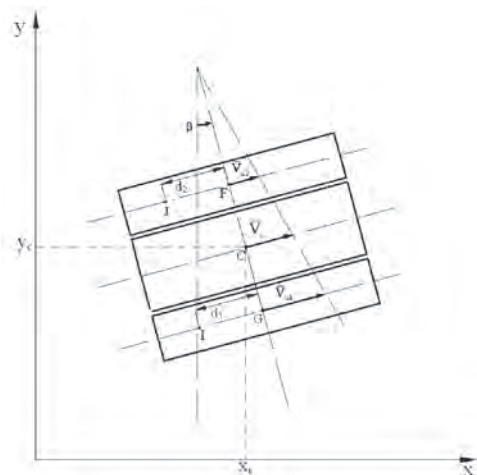

Fig. 9. Diagram of the frame robot turn for the angle β
Rys. 9. Schemat obrotu ramy robota o kąt β

$$\dot{y}_C = \frac{r\dot{\alpha}_1(1-s_1) + r\dot{\alpha}_2(1-s_2)}{2} \sin \beta \quad (13)$$

$$\dot{\beta} = \frac{r\dot{\alpha}_2(1-s_2) - r\dot{\alpha}_1(1-s_1)}{H} \quad (14)$$

Based on the relation (12) and (13) it is possible to write as the equation of reverse kinematics tasks:

$$V_C = \sqrt{\dot{x}_C^2 + \dot{y}_C^2} \quad (15)$$

$$\dot{\alpha}_1 = \frac{V_C - 0,5 \cdot \dot{\beta}H}{r(1-s_1)} \quad (16)$$

$$\dot{\alpha}_2 = \frac{V_C + 0,5 \cdot \dot{\beta}H}{r(1-s_2)} \quad (17)$$

Considering correlations of the transmission crawler track arrangement:

$$\frac{1}{264} \dot{\alpha}_{1s} = \dot{\alpha}_1 \quad (18)$$

$$\frac{1}{264} \dot{\alpha}_{2s} = \dot{\alpha}_2 \quad (19)$$

where: $\dot{\alpha}_{1s}$ – angular speed on the shaft of driving engine running crawler track, $\dot{\alpha}_{2s}$ – angular speed on the shaft of driving engine running crawler track

Substituting (16) and (17) to (18) and (19) received relations on the angular speeds of driving engines:

$$\dot{\alpha}_{1s} = \frac{264(V_C - 0,5 \cdot H)}{r(1-s_1)} \quad (20)$$

$$\dot{\alpha}_{2s} = \frac{264(V_C + 0,5 \cdot H)}{r(1-s_2)} \quad (21)$$

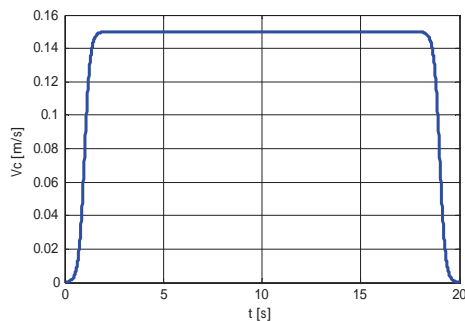

Fig. 11. Set speed of the point C

Rys.11. Prędkość zadana punktu C

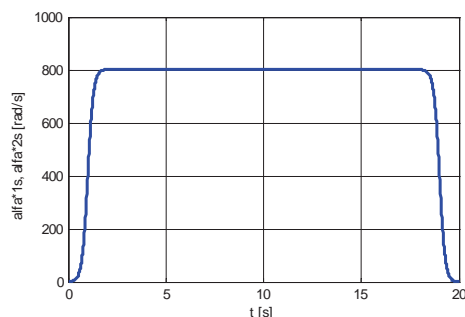

Fig. 12. Angular speed on shafts of driving engines

Rys.12. Prędkość kątowna na wałach silników napędzających

4. Numerical verification of the kinematics model

In many cases during the inspection work the zone of robot action isn't limited to horizontal planes. Many times the robot must defeat different heights and therefore in order to obtain more comprehensive analysis of the kinematics robot must carry it also in case of the move after the hill.

For the numerical verification the following assumptions were made. The robot moves on the segment about γ gradient, at equal angular speeds of driving wheels $V_{w1} = V_{w2}$, slip $s_1 = s_2 = s$ then the equations of movement will adopt the form:

$$\dot{\alpha}_{1s} = \frac{264(V_C - 0,5 \cdot H)}{r \left(1 - \frac{(n-1)\Delta l}{L} \right)}, \quad \dot{\alpha}_{2s} = \frac{264(V_C + 0,5 \cdot H)}{r \left(1 - \frac{(n-1)\Delta l}{L} \right)}$$

Assuming that its point C moves on the trajectory (fig. 10a), with the speed course (fig. 10b).

Received courses for the set trajectory and speed of the point C.

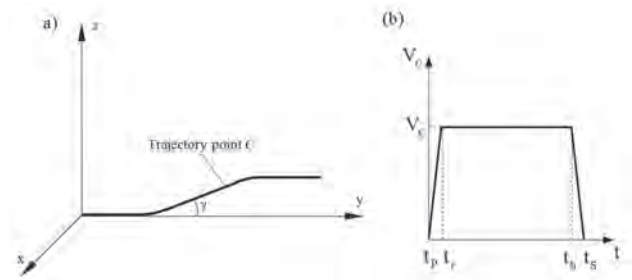

Fig. 10. a) Set motion track of the point C, b) set speed course of the point C

Rys. 10. a) Założony tor ruchu punktu C, b) założony przebieg prędkości punktu C

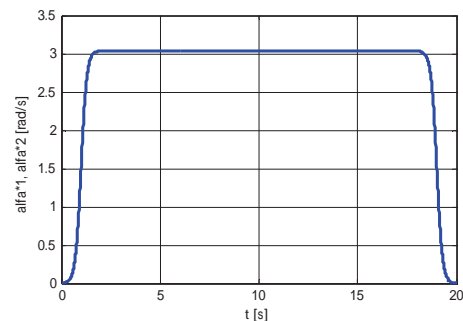

Fig. 13. Angular speed of crawler tracks

Rys. 13. Prędkość kątowna kół napędzających gąsienice

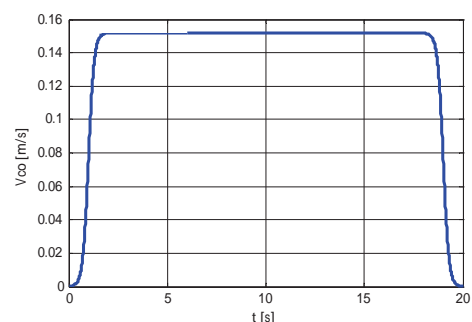

Fig. 14. Received speed driving wheels

Rys.14. Prędkość otrzymana

5. Summary

Equations of the kinematics inspection robot were drawn up correctly, simulation examinations confirmed it. The numerical verification showed influence of the slip on behavior of the robot. As can be observed for increasingly larger set disposable horizontal deforming ground or clutch, the speed of slip increases its value. More considerable value assumes also received speed of the point C in order to ensure the set speed. However, the increase speed in fact is limited by parameters of the driving arrangement (rotation speed, engine power driving) what leads to situation that the robot starts to move with smaller lost speed in aid of the slip speed.

Bibliography

1. Burdziński Z., *Teoria ruchu pojazdu gąsienicowego*, Wydawnictwa Komunikacji i Łączności, Warszawa 1972.
2. Dajniak H., *Ciągniki teoria ruchu i konstruowanie*, Wydawnictwa Komunikacji i Łączności, Warszawa 1985.
3. Żylski W., *Kinematyka i dynamika mobilnych robotów kołowych*, Oficyna Wydawnicza Politechniki Rzeszowskiej, Rzeszów 1996.
4. Trojnecki M.: *Modelowanie i symulacja ruchu mobilnego robota trzykołowego z napędem na przednie koła z uwzględnieniem poślizgu kół jezdnych*, „Modelowanie Inżynierskie”, Tom 10, Nr 41, 411–420, ISSN 1896-771X, Gliwice 2011.
5. Chodkowski A.W., *Badania modelowe pojazdów gąsienicowych i kołowych*, Wydawnictwa Komunikacji i Łączności, Warszawa 1982.
6. Chodkowski A.W., *Konstrukcja i obliczanie szybkojeżdzących pojazdów gąsienicowych*, Wydawnictwa Komunikacji i Łączności, Warszawa 1990.
7. Documentation made available by MPWiK SA Krakow [www.wodociagi.krakow.pl].

Kinematyka podwodnego robota inspekcyjnego

Streszczenie: W artykule przedstawiono zagadnienia związane z modelowaniem i weryfikacją numeryczną kinematyki robota inspekcyjnego do diagnostyki i konserwacji zbiorników z cieczą. Robot zbudowany został w Katedrze Robotyki i Mechatroniki AGH w ramach grantu finansowanego przez NCBiR. Analizę kinematyczną przeprowadzono przy użyciu dostępnych i opisanych w literaturze metod matematycznych oraz na podstawie istniejących konstrukcji robotów. Zastosowane rozwiązania konstrukcyjne pozwalają sterować dwoma gąsienicami, modułem czyszczenia dna zbiornika i modułem diagnostycznym. Weryfikację kinematyki przeprowadzono przy użyciu metod inżynierskich oraz oprogramowania MATLAB. Otrzymane wyniki przedstawiono w postaci równań matematycznych oraz charakterystyk pokazujących kinematyczne parametry ruchu robota. Praca przedstawia również kierunki dalszych badań nad zaprojektowanym i skonstruowanym robotem.

Słowa kluczowe: mobilne roboty, kinematyka, roboty inspekcyjne, roboty podwodne

Prof. Mariusz Giergiel, PhD

He was born in 1961 in Cracow, Poland. He was graduated in 1985 at AGH University of Science and Technology in field of electronics automatics. In 1992 earned his doctoral degree in field of mechanics at the same University. Since 2005 he is professor at AGH UST at Faculty of Mechanical Engineering and Robotics. Works in filed of automatics and robotics, applied mechanics and mechatronics. Currently is research manager of group working on project of underwater tank inspection robots. Member of local and international scientific societies, author of many publications, patents, developed researches and applied solutions.

e-mail: giergiel@agh.edu.pl



Krzysztof Kurc, PhD

In 1999 graduated from technical school in electronics Krosno, in 2004, graduated from the Faculty of Mechanical Engineering and Aeronautics, Rzeszow University of Technology. Since 2004, working in the Department of Applied Mechanics and Robotics, Rzeszow University of Technology. Research interests include mechatronics, robotics, mechanics, design.

e-mail: kkurc@prz.edu.pl



Piotr Małka, PhD

He received MSc degree in Robotics and Automatics from the Faculty of Mechanical Engineering and Robotics, AGH University of Science and Technology in 2001, the PhD degree in 2008 also at AGH University. He is currently employed at Municipal Waterworks and Sewer Enterprise, holds the position of manager for the automation. His main research area is connected with industrial and mobile robots, fuzzy logic applications, modelling and identification of mechatronic systems.

e-mail: malka@agh.edu.pl



Tomasz Buratowski, PhD

He received MSc degree in Robotics and Automatics from the Faculty of Mechanical Engineering and Robotics, AGH University of Science and Technology in 1999, the PhD degree in 2003 also at AGH University. He is currently employed at AGH university as an assistant professor. His main research area is connected with industrial and mobile robots and also human-robot interaction, fuzzy logic applications, modelling and identification of mechatronic systems.

e-mail: tburatow@agh.edu.pl



Dariusz Szybicki, MSc

He was born in Przeworsk. He graduated from the University of Rzeszów, where in 2009 he started engineering doctoral studies at the Faculty of Mechanical Engineering and Aeronautics. He works as an assistant in the Department of Applied Mechanics and Robotics at the Technical University of Rzeszów. His research interests relate to robotics, programming, and modeling of mechatronic systems.

e-mail: dszybicki@prz.edu.pl

