

Design of the robotic exoskeleton for upper-extremity rehabilitation

Artur Gmerek

Institute of Automatic Control, Lodz University of Technology

Abstract: This paper touches upon the issue of designing of an upper-limb exoskeleton used for rehabilitation. Mainly there are presented the results concerning the mechanical design. The exoskeleton, also known as orthosis, has 12 degrees of freedom (DOF). Among 12 DOF there can be distinguished 7 DOF which are actively controlled during rehabilitation, 3 passive DOF which are responsible for wrist movements, and 2 adjustable DOF used for links elongation. An orthosis has been specifically designed to accomplish requirements of medical applications. Described exoskeleton is a key-component of the upper-limb rehabilitation robot.

Keywords: exoskeleton, rehabilitation of upper-extremity, upper-limb, orthosis design

1. Introduction

The motivation underlying the analysis described in this paper is concerned with designing an upper-limb orthosis for a rehabilitation robot. Active orthoses are orthotic devices with motors used for link rotation. In this article special attention was paid to exoskeletons used for rehabilitation. Such devices, unlike machines with a single contact with user's body, are able to precisely control the position of an upper-limb (an arm in relation to a forearm).

On the market, in scientific literature and databases of patents there can not be distinguished many orthosis that are advanced in the way that they could be used in rehabilitation. One of the most famous and advanced exoskeleton on the world is SARCOS – created by DARPA [1]. SARCOS is able to support user's motion. User's force can be increased even dozens of times. SARCOS suit is however designed to military purposes.

It is also known the exoskeleton suit developed by Tsukuba University in Japan [2]. The exoskeleton called HAL (Hybrid Assistive Limb) is yet another one, designed to expand physical capability of users.

The most interesting ones from the point of view of this paper are exoskeletons designed for rehabilitation. There are at least several inventions that should be mentioned.

One of such interesting structures was invented by Han Jungsoo et al. [3]. They proposed a robot, with high range of motion. Inventors achieve it by reducing volume of the actuators. The robot is used for shoulder and elbow rehabilitation. It is characterized by compact and elegant structure.

Carignan et al. developed a special anthropomorphic exoskeleton with a modular approach to control [4]. The construction has scapula and glenohumeral joints. In the grip handle there is a force sensor. Controller can operate in both impedance and admittance mode.

IntelliArm is one of the most advanced robots [5, 6]. The robot has 10 DOF, including hand opening and closing mechanism. It is used for shoulder, elbow and wrist rehabilitation. What is interesting the robot is able to drive in four glenohumeral movements including flexion/extension, internal/external rotation, abduction/adduction and vertical displacement of the glenohumeral joint.

And finally, one of the most advanced families of that kind of robots has been developed by scientist mainly related to the ETH Zurich. They are known by a common name – ARMin. The motor/gear combination is backdrivable, ensured by harmonic drive modules. ARMin I has 6 degrees of freedom [7, 8]. The last ARMin III has 4 DOF (shoulder and elbow joints), but the wrist module can be also attached to the construction. Scientist from ARMin project proposed many types of advanced force-control algorithms.

In the next sections there is explained why the decision has been made for a particular type of solution.

2. Assumptions about the design

The most difficult decision to be made is about the proper design of arm joints. Considerations about properly designed rehabilitation exoskeleton should begin from

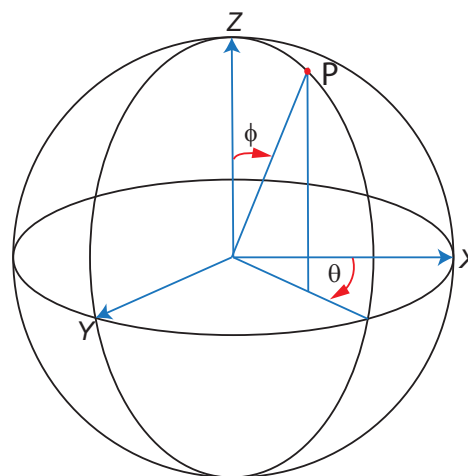

Fig. 1. Spherical coordinate system
Rys. 1. Sferyczny układ współrzędnych

answering the question of how many degrees of freedom are needed to control the position and orientation of an arm. In order to setup a particular position in the sphere, 2 DOF are needed (fig. 1).

However, there is also needed one more joint to setup correct orientation. Because of this, minimum 3 DOF are necessary to control arm position. In this structure 1 DOF can be passive, nevertheless in such a case, some position and orientation could not be obtained directly, e.g. abduction/adduction of a limb. The result of this brief analysis lead to the conclusion that in order to provide robust control, min. 3 active DOF are needed.

In some limb configuration the pivot point of an arm is changed. Because of this should be provided additional active joints for proper limb position and orientation control in their all range of motion (ROM).

The exoskeleton's ROM should be the same as ROM of a human's arm [9]. If ROM was less than human's limb ROM, the exoskeleton would not reach all the positions. On the other hand, exoskeleton's ROM, which is greater than a limb's ROM could possibly lead to injury in case of control system malfunctions.

It is also desirable that orthosis be symmetrical, which is associated with capability of both limbs rehabilitation – left and right.

While designing an orthosis, it should be also noticed that design should occupy as little space as possible and fit the human limb well.

Another very important feature is also connected with choosing an appropriate drive. In this project force is estimated based on motor current. This greatly decreases the costs of force sensors. In order to provide such possibility, the transmissions of motors have to have small ratio. This, in turn, causes that the motor power should be higher in order to produce sufficient torque.

When taking into account all the observations, volumes and masses of motors as well as corresponding relationships between individual joints, proper design of an orthosis suitable for rehabilitation becomes a significant problem.

3. Development of the orthosis construction

It is very difficult to meet all the assumptions presented in the previous section mainly because of the large volumes and masses of the actuators. One way to solve this problem is placing drives outside an orthosis [10, 11]. In such structures, torque is transmitted via a system of strings and pulleys. This kind of arrangement, nonethe-

less, makes design so complicated that it is very difficult to design a rehabilitation orthosis capable to rehabilitate both limbs and to move through the entire ROM of human limb. For this reason it has been decided that the drives will be placed directly on the exoskeleton.

Some considerations can be also made whether to use prismatic or revolute joints to drive links of the orthosis. Prismatic joints are very difficult to use in symmetric structure and to provide full ROM. Because of this there have been used the revolute joints.

Development of an orthosis kinematic structure can be started with an arm configuration. In fig. 2 some of the possible forms of an arm kinematic structures are present,

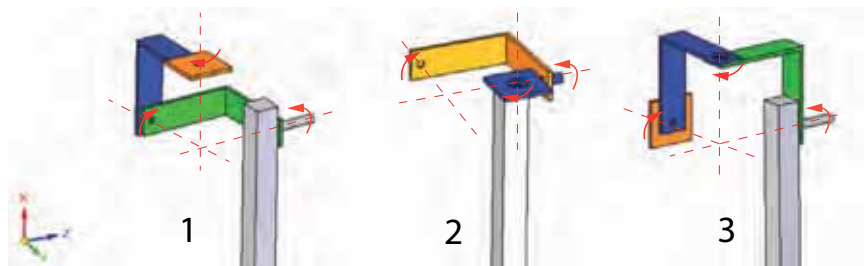

Fig. 2. Sample configuration of the shoulder. The first link is marked in orange, second – blue, third – green and the orthosis, which has contact with human arm is gray

Rys. 2. Przykładowe konfiguracje stawu barkowego. Pierwsze ogniwo zostało oznaczone kolorem pomarańczowym, drugie – niebieskim i trzecie – zielonym, a orteza, która ma kontakt z ramieniem pacjenta jest szara

ted, when taking into account presumptions given in the previous section. Links are set in such a way as to provide three mutually perpendicular degrees of freedom.

Because of lack of self-locking of gears, arm configuration should be stable in case of power failure. This excludes 1st and 2nd configuration. Besides it would be very difficult to place a third actuator in 2nd configuration of exoskeleton, due to the large volume of motors and gears. This and other reasoning has led the author to the 3rd configuration.

Proper placement of motors requires, however, modifications of presented arm configuration. The first modi-

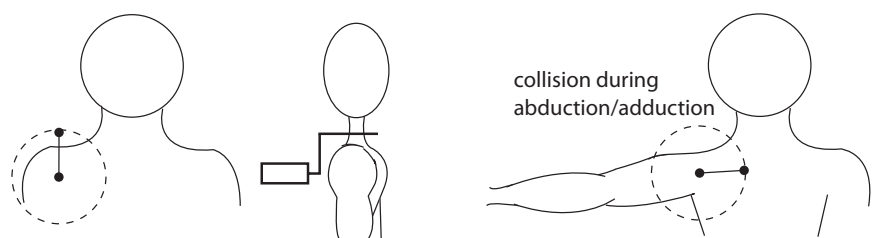

Fig. 3. Schematic representation of the collision of the orthosis' link with patient's shoulder during abduction/adduction movement

Rys. 3. Schematyczna prezentacja kolizji pierwszego ogniwa ortezy z ramieniem pacjenta

figuration is connected with a situation when during some movements (e.g. abduction/adduction), second joint could have contact with human shoulder (fig. 3).

One of the possible solutions to this problem is placing the first joint in such a way that the second joint would turn around its own axis. This would, unfortunately, cause that the first joint pivot point does not coincide with arm pivot point. However, it is impossible to place all three links in such a way, that they would preserve all assump-

tions and be in the pivot point of an arm. For this reason, it has been applied configuration shown in fig. 4.

The first motor in not in the pivot point of an arm. These displacements of the pivot points must be compensated. In this project, it has been done with the use of 3-DOF linear gantry system (fig. 5). The orthosis is connected to this gantry system. The gantry system also provides adaptation to changes in the position of the pivot point in some limb configuration (above a shoulder girdle).

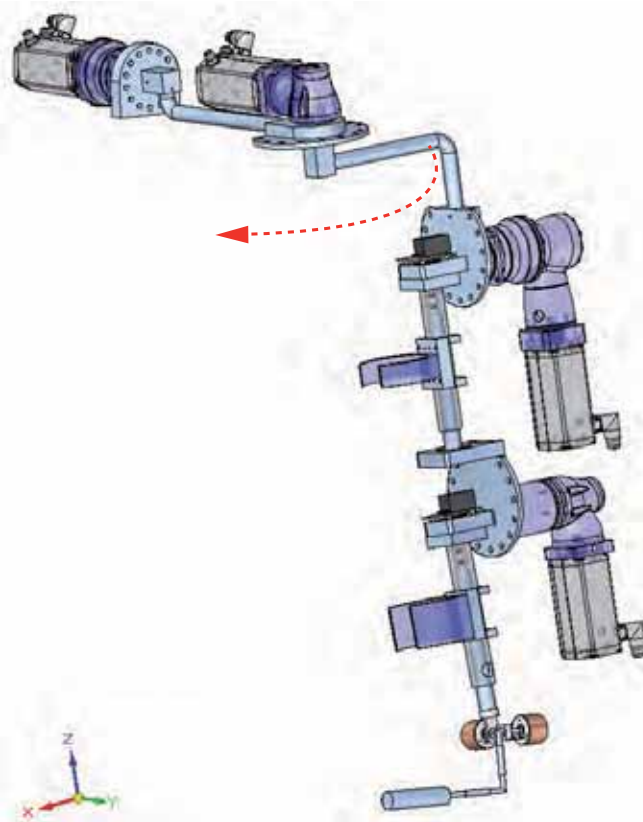

Fig. 4. Designed prototype of active orthosis
Rys. 4. Prototyp egzoszkieletu

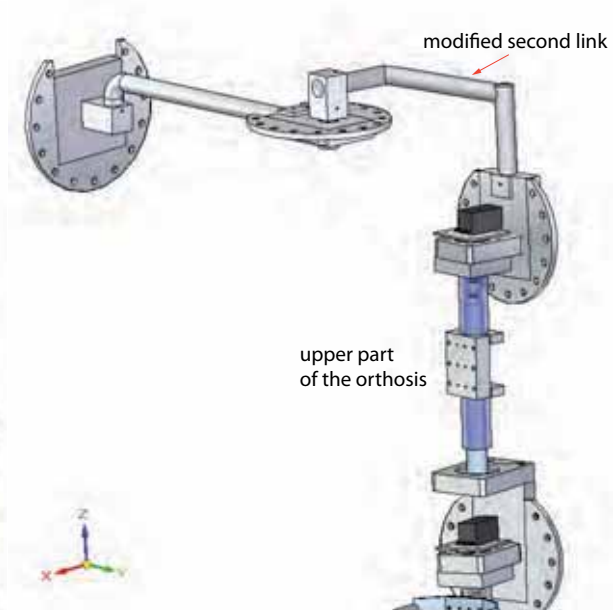

Fig. 6. The modified second link of the orthosis
Rys. 6. Zmodyfikowane trzecie ogniwo ortozy

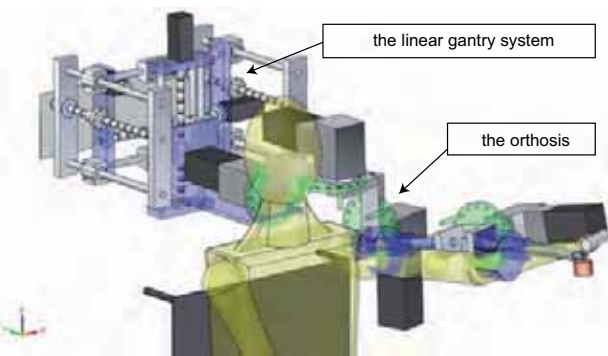

Fig. 5. Linear gantry system
Rys. 5. Liniowy układ bramowy, na którym spoczywa orteza

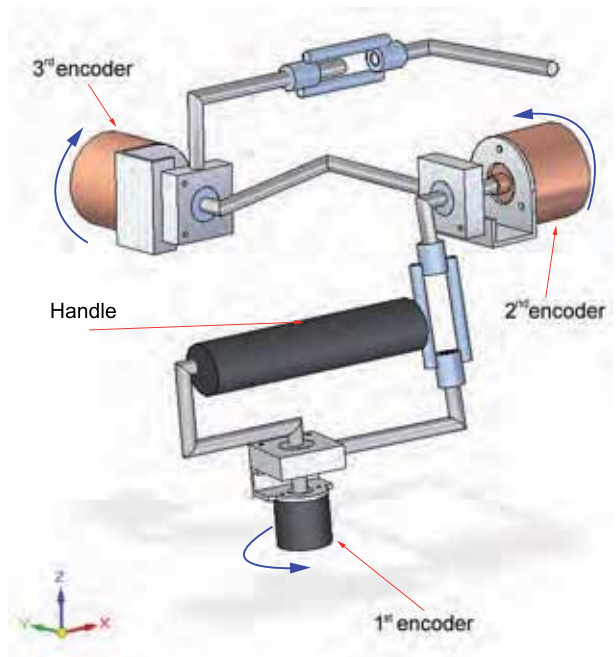

Fig. 7. Activity of Daily Living Handle
Rys. 7. Aktywny uchwyt na rękę przeznaczony do systemu wirtualnej rzeczywistości



Fig. 8. Subjects during experiments

Rys. 8. Pacjenci podczas eksperymentów

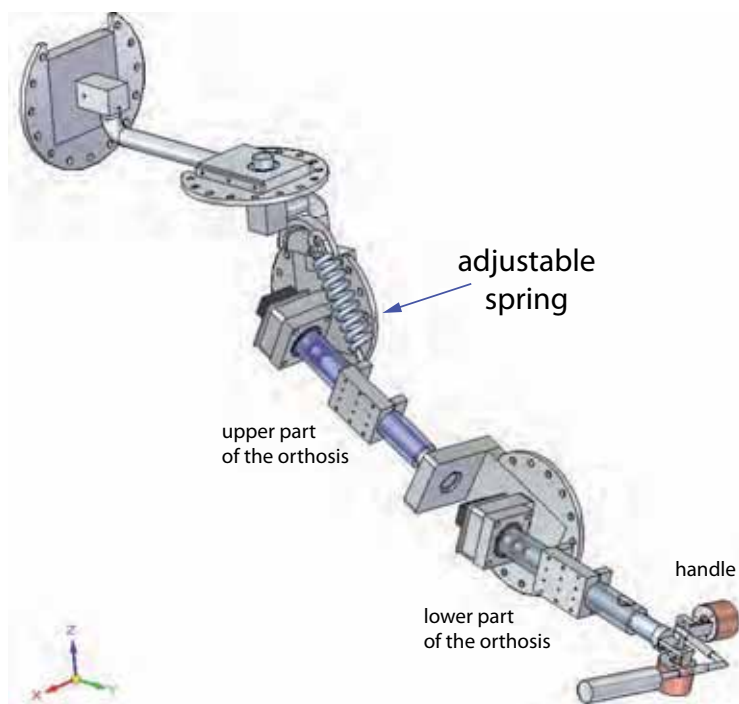

Fig. 9. Conceptual orthosis model with an adjustable spring for gravity compensation

Rys. 9. Konceptyjny model ortozy ze sprężyną odpowiedzialną za kompensację grawitacji

In the presented prototype the second motor is close to the patient's head. One of the solution could be the modification of the third link of the arm configuration by adding one additional dimension (fig. 6).

This, however, would caused that the second joint pivot point would not coincide with arm pivot point, nevertheless it could be compensated with aforementioned gantry system.

Electrical actuators have been used because of high accuracy and repeatability. It is important in this project to smoothly control motors in position, velocity and current mode. Especially smooth velocity characteristics are needed in small ranges of speed, because of low gears ratios. Because of this there has been used the BLDC (brushless DC) motors.

In arm and forearm parts of the orthosis, screws with long nut are placed, being responsible for adaptation to different anthropometric parameters of patient's body. The screws are driven by DC motors with self-locking gearing. The gears prevent screws from rotation when the power is off. The second end of the screw is, however, free. To fully control its rotation, the electromagnets have been used.

The orthosis can be also provided with special activity of daily living handle, which can be used for transmitting the orientation of wrist to control system (fig. 7).

Orthosis is also equipped with motion limiters in which bolts responsible for restricting the movement can be screwed.

4. Experiments and conclusions

Experiments have been made on different users in order to collect as many feedback as possible (fig. 8). Most of the users complain about the large mass of the exoskeleton.

Experiments also showed that one prismatic joint in gantry system is almost unused. Accordingly, it can be removed.

Future work will focus on reducing the mass of actuators by modifying the construction, by providing special springs for gravity compensation (fig. 9).

This will almost doubly reduce the weight of the unit, while maintaining the same functionality.

Acknowledgements

This work is financially supported by the Ministry of Science and Higher Education of Poland (Grant No. N N514 469339).

I am grateful for advice on this project to prof. Edward Jezierski from Institute of Automatic Control of Technical University of Lodz.

Bibliography

1. [www.raytheon.com] – information about SARCOS exoskeleton.
2. [www.cyberdyne.jp] – information about HAL exoskeleton suit.
3. Jungsoo H. et al., *Wearable robotic system for rehabilitation training of the upper limbs*, Worldwide Patent WO2010071252.
4. Carignan C. et al., *A configuration-space approach to controlling a rehabilitation arm exoskeleton*, Proc. IEEE 10th Int. Conf. Rehabilitation Robotics ICORR, 2007, 179–187.
5. Ren Y. et al., *Developing a whole-arm exoskeleton robot with hand opening and closing mechanism for upper limb stroke rehabilitation*, Proc. IEEE Int. Conf. Rehabilitation Robotics ICORR, 2009, 761–765.
6. Li-Qun Z., Hyung-Soon P., Yupeng R., *Robotic rehabilitation apparatus and method*, U.S. Patent US2010016766(A1), 2010.
7. Nef T. et al., *ARMin – robot for rehabilitation of the upper extremities*, Proc. IEEE Int. Conf. Robotics and Automation ICRA 2006, 3152–3157.
8. Nef T., Riener R., *ARMin - design of a novel arm rehabilitation robot*, Proc. 9th Int. Conf. Rehabilitation Robotics ICORR 2005, 57–60.
9. Parasuraman S. et al., *Human upper limb and arm kinematics for robot based rehabilitation*, Proc. IEEE/ASME Int. Conf. Advanced Intelligent Mechatronics AIM 2009, 845–850.
10. Jarrasse N. et al., *Design and acceptability assessment of a new reversible orthosis*, Proc. IEEE/RSJ Int. Conf. Intelligent Robots and Systems IROS 2008, 1933–1939.
11. Univ K. et al., *Robotic exoskeleton for limb movement*, Worldwide Patent WO2008131563(A1), 2008. ■

Projekt egzozkieletu przeznaczonego do rehabilitacji kończyny górnej

Streszczenie: Artykuł opisuje zagadnienia konstrukcyjne związane z projektem egzozkieletu przeznaczonego do rehabilitacji kończyny górnej. Egzozkielet, zwany również ortezą, posiada 12 stopni swobody. Wśród nich można wyróżnić 7, które są aktywnie sterowane w trakcie przebiegu rehabilitacji, 3 bierne związane z ruchami nadgarstka oraz 2 stopnie swobody nastawcze, związane z dostosowywaniem ortozy do długości kończyny pacjenta. Opisywany egzozkielet jest kluczową częścią opracowanego robota rehabilitacyjnego.

Słowa kluczowe: egzozkielet, rehabilitacja kończyny górnej, kończyna górna, projektowanie ortez

Artur Gmerek, MSc

He received the MSc degree in the field of Automatics and Robotics, majoring in Control of Industrial Processes and Applied Computer Science from Lodz University of Technology, Poland, in 2008. His research interests include rehabilitation robots and biomedical systems. He currently studies for a PhD at the Lodz University of Technology at Institute of Automatic Control.

e-mail: artur.gmerek@p.lodz.pl

